

MECHANICAL SHEARING MACHINES

3P serie up to 6300 kN and 600 spm

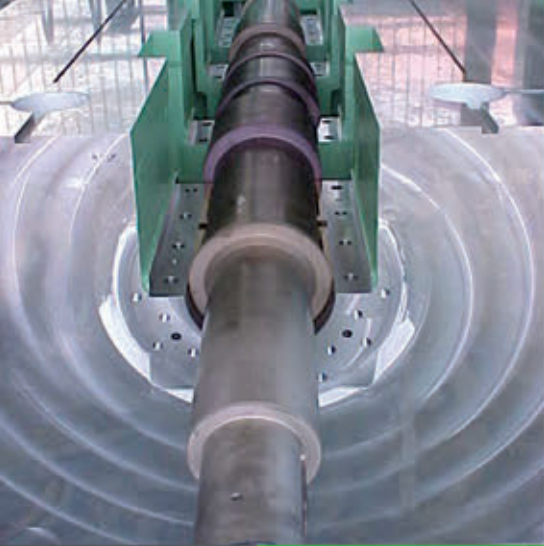

Metal shearing with Zame presses

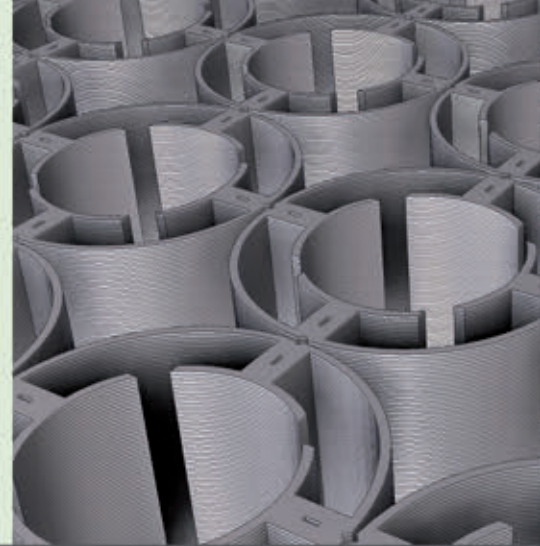

Trademark of quality and advanced technology

ZAME® INTERNATIONAL presses are reliable and entirely built in Italy.

These mechanical presses are the result of a long experience in the field and above all the application of the ZAME know how. They distinguish themselves for their high precision in the production and assure the customer with a considerable quality batch production.

The customer, in order to achieve his satisfaction, is followed step by step by our experienced engineers during all the process. Spare parts and after sale service are always granted

- High productivity and quality of the batch production for a granted long durability of the die tool
- An advanced project for reduced maintenance costs
- Granted precision thanks to our high stiffness and no structural deflection
- Simple and comprehensible control systems
- Quick services and supplies

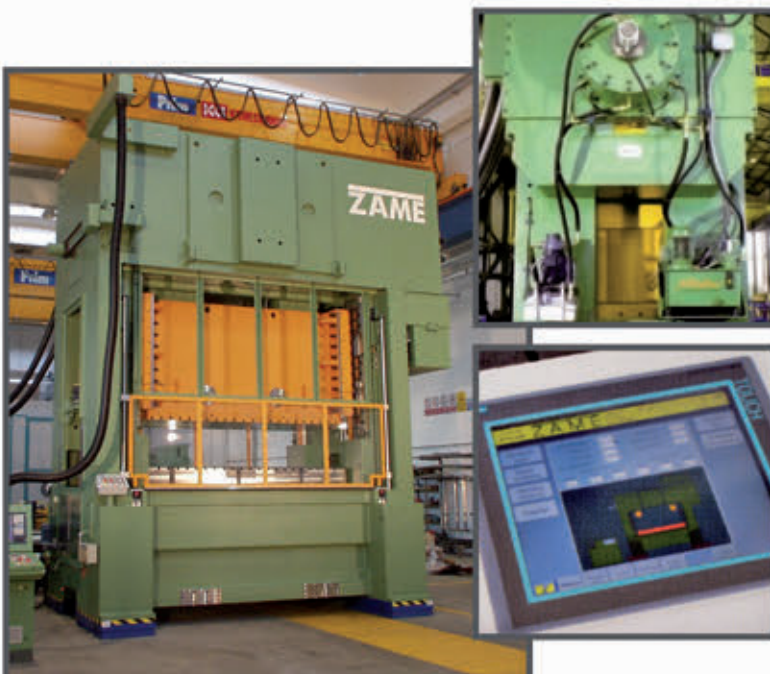



High productivity, precision and long life of die tool

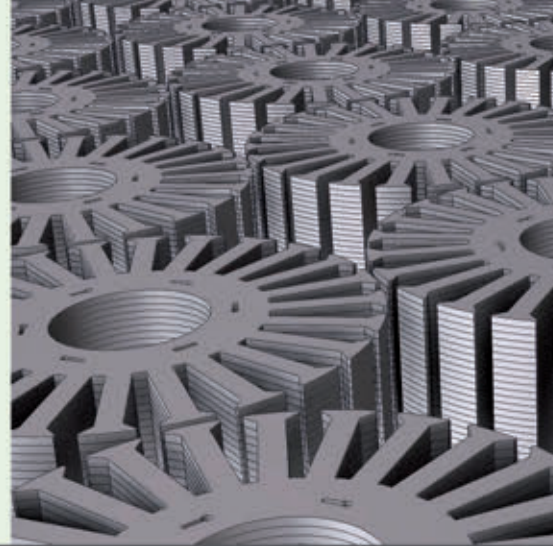

- **Four pieces frame assembled by preloaded tie rods**
- **Built with welded and annealed plates, our presses guarantee a great stiffness and the total absence of deflections**
- **Flywheel supported by a fixed-on-the-structure support. The flywheel doesn't weigh on the shaft and turns over the bearings. Hydraulic operated brake-clutch group.**
- **Highly resistant and surface hardened steel shaft is housed in bronze bushes with low clearances.**
- **Cast iron slide and balance weight. Eight guides slide with longitudinally and transversally adjustable clearances.**
- **Dynamic balance weight housed in the head**
- **High quality trade components**

High stiffness, compactness and granted parallelism

Its peculiar structure, the frame construction and the parts' centering guarantee strength to the press. The parallelism between the basement and the slide has been designed to be less than a hundredth of millimeter. Every part of the press, from the material to the mechanical components, is the best the market offers.

Control group

The flywheel 's movement and the motor, designed by ZAME®INTERNATIONAL, guarantees operating value and maximum power, till a reduced rotation speed. The speed is assured by the compact control group provided with a brake-clutch group, and an inertia flywheel fed by an asynchronous motor. The shaft and the connecting rods assure a high quality of the production thanks to the contained clearances

Stabilized cast iron slide with bronze guides. Slide adjustment quick lift system

The solid cast iron slide of ZAME®INTERNATIONAL is provided with eight special bronze guides that guarantee contained clearances. This is the result of the centering of the slide, obtained thanks to the oil hydrostatic thrust. The regulation made by an hydraulic engine guarantee a precise positioning. The slide is provided with an hydraulic locking system. The slide can be equipped with a servo hydraulic quick lift for die inspections.

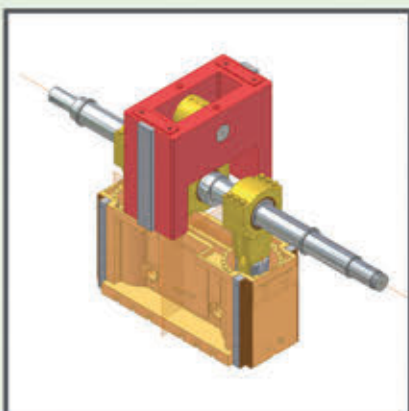

Bolster up to 4000 mm

Stroke up to 300 mm

Up to 600 spm

3P with counter balance

2P without counterweight balance

A centralized lubrication system

The lubrication circuit equipped with controlled flowmeters grants a great safety in functioning. The oil recovery is done inside the structure, avoiding drafts over die tools and products.

Display and automation programmable by electric cams

The controlling functions are automatized and programmable by dynamic electronic cams. The tool change is quick and simple, thanks to the display on touch screen. The parameters of every tool are memorized by the system which guides the operator through the process of the tool change. The display offers some advanced functions which support the control, the diagnostic and the maintenance. It's also possible to ask for a wireless diagnostic support.



BLANKING PRESSES 3P

TYPE	POWER kN	BOLSTER mm	SHUTHEIGHT mm*	UPRIGHT OPENING mm	STROKE mm	SPEED spm	QUICK LIFT mm
3P60	600	750 x 700	340	300	25 – 30	100 – 600	
3P100	1000	1250 x 750	370	350	25 – 30	100 – 600	
3P130	1300	1400 x 900	380	400	25 – 30	100 – 550	50
3P160	1600	1500 x 1000	400	450	25 - 30	100 - 520	50
3P200	2000	1800 x 1100	450	450	30	100 - 500	50
3P250	2500	2000 x 1100	470	500	30	80 - 450	50
3P320	3200	2200 x 1200	480	500	30	80 - 430	70
3P400	4000	2500 x 1400	530	620	30	60 - 350	70
3P500	5000	3000 x 1500	550	820	30	60 - 330	100
3P630	6300	3500 x 1500	580	1020	30	60 - 220	100

OPTIONS: CS = Tonnage Control AR = Quick Lift AM = Dumpers
 BS = Die-Tool Hydraulic Blocking System MS = Die-Tool Brackets

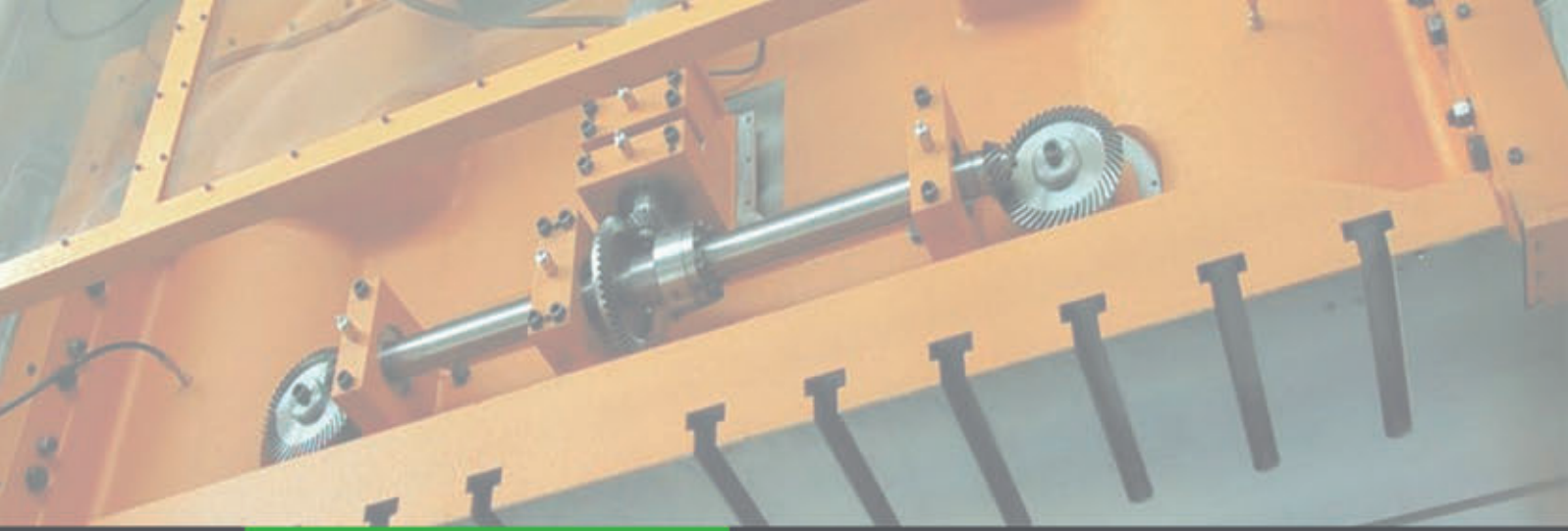

PRODUCTION AND SERVICES

Presses' construction

ZAME®INTERNATIONAL
realizes customised presses

- Quick balanced presses
- Quick non-balanced presses
- Geared presses
- Special presses

Revamping

Production and safety
implementation for presses of
every brand or weight

- Overhaul and revamping
- Retrofit and modernisation
with advanced control
technology according to the
CE requirements

Services

- Spare parts production
- Repair and assistance
- Mechanical and electronic
check-up

Occasion machineries

- Sale and purchase
- Intermediation

ZAME INTERNATIONAL SRL
Via Bonifacio da Modena
22100 Como
Tel. 0039.031.523050
Fax 0039.031.526610
zame@zameinternational.com
www.zameinternational.com

ZAME